

CDD10R-S CDD12R-S Electric Stacker with Initial Lift

Characteristics

- The truck features compact design, small dimensions and excellent visibility.
- The truck adopts 4-points support structure, side positioned tiller and low center of gravity design which featuring excellent stability.
- Double pallet design: two pallet can be handled at one time; initial lift of load leg increases ground clearance to facilitate traffic ability on ramps, dock levelers and bridge.
- Vertical driving wheel offers small turning radius; dustproof waterproof motor is easy for maintenance.
- High efficient electromagnetic parking brake offers good ramp braking performance.
- Low voltage protection setting prolongs the battery life.
- Height adjustable balance wheel ensures the drive wheel life.



Manufacturer's Data and Technical Characteristics				
Character				
1.01	Manufacturer			HELI
1.02	Model		CDD10R-S	CDD12R-S
1.03	Mast type		2-stage mast	
1.04	Load capacity	Q	kg	1000
1.05	Load center distance	C	mm	600
1.06	Driving mode			Walkie
1.07	Front overhang	x	mm	788
1.08	Wheel base	Y	mm	1268
Tyre				
2.01	Tyre type			Polyurethane
2.02	Wheels number, Front/rear(X=driven wheels)			1x+1/4
2.03	Track Width, front	b10	mm	523
2.04	Track Width, rear	b11	mm	390
2.04	Wheel size, front		mm	ø195x70
2.05	Wheel size, rear		mm	ø80x70
2.06	Wheel size, additional		mm	ø150x60
Dimension				
3.01	Lift height	h3	mm	1600/2500/3000/3300
3.02	Height, mast extended	h4	mm	2122/3092/3592/3892
3.03	Height, mast lowered	h1	mm	2122/1872/2122/2272
3.04	Height, lowered	h13	mm	90
3.05	Initial lift	h5	mm	120
3.06	Fork size	s/e/l	mm	60/180/1070(1150)
3.07	Overall length	l1	mm	1709/1789
3.08	Length to face of forks	l2	mm	639
3.09	Overall width	b1	mm	800
3.10	Width across forks	b5	mm	570
3.11	Turning radius	Wa	mm	1450
3.12	Aisle width with pallet 800Wx1200L, clearance 200	Ast	mm	2224
3.13	round clearance	m2	mm	17~137
Performance				
4.01	Travelling speed, laden/unladen		km/h	4.5/5
4.02	Lifting speed, laden/unladen		m/s	0.11/0.14
4.03	Lowering speed, laden/unladen		m/s	0.12/0.10
4.04	Gradeability, laden/unladen		%	6/15
Electrical configuration				
5.01	Drive motor power		kw	0.65
5.02	Lifting motor power		kw	2.2
5.03	Battery voltage		V	24
5.04	Battery capacity		Ah	105(125)
5.05	Battery dimensions l/w/h		mm	329x172x214
5.06	Controller			CURTIS
5.07	Brake			Electromagnetic
Weight				
6.01	Total weight(with battery)		kg	605/670/690/702
6.02	Battery weight		kg	60.8

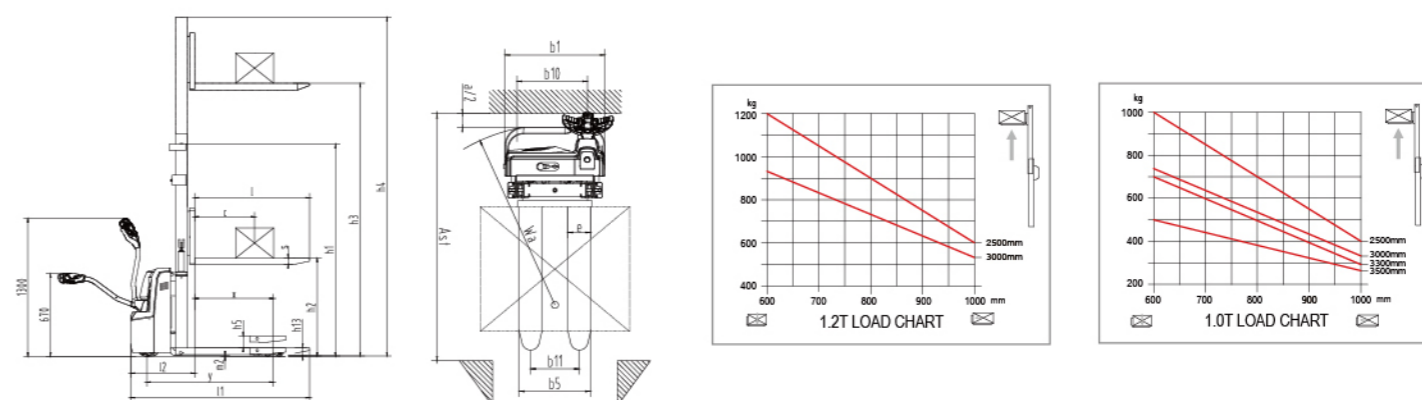

ANHUI HELI CO., LTD.

Add / No.668, FangXing Road, Hefei, China
Fax / +86-551-63639966

Tel / +86-551-63639068(America); 63639258(Europe);
63639358(Asia); 63662105(Africa & Middle East);
63639530(Key Accounts Division); 63662105(Wheel loader)